

# PROGRAMMING INSTRUCTIONS

## VK3

### 1. Description of Operation

The purpose of EMCO Load System is to measure, monitor and provide usable information about the load in an elevator cab. This information can be used to protect the passengers from overload conditions and increase the efficiency of the elevator. The system usually consists of a sensor or group of sensors to be mounted on the elevator and a controller. The sensor(s) are used to provide a signal to the controller directly related to the amount of load in the cab. The controller is used to accept this signal and provide usable data to the elevator controller in the form of relays, analog signals or other methods of communication.

### 2. Electrical Characteristics

<u>Model</u>	<u>Power Supply</u>	<u>Current</u>	<u>Fuse</u>
VK-3	220VAC	60mA	100mA
VK-3	115 VAC	120mA	200mA
VK-3B	24VDC	300mA	800mA
	48VDC	150mA	400mA

### 3. Installation

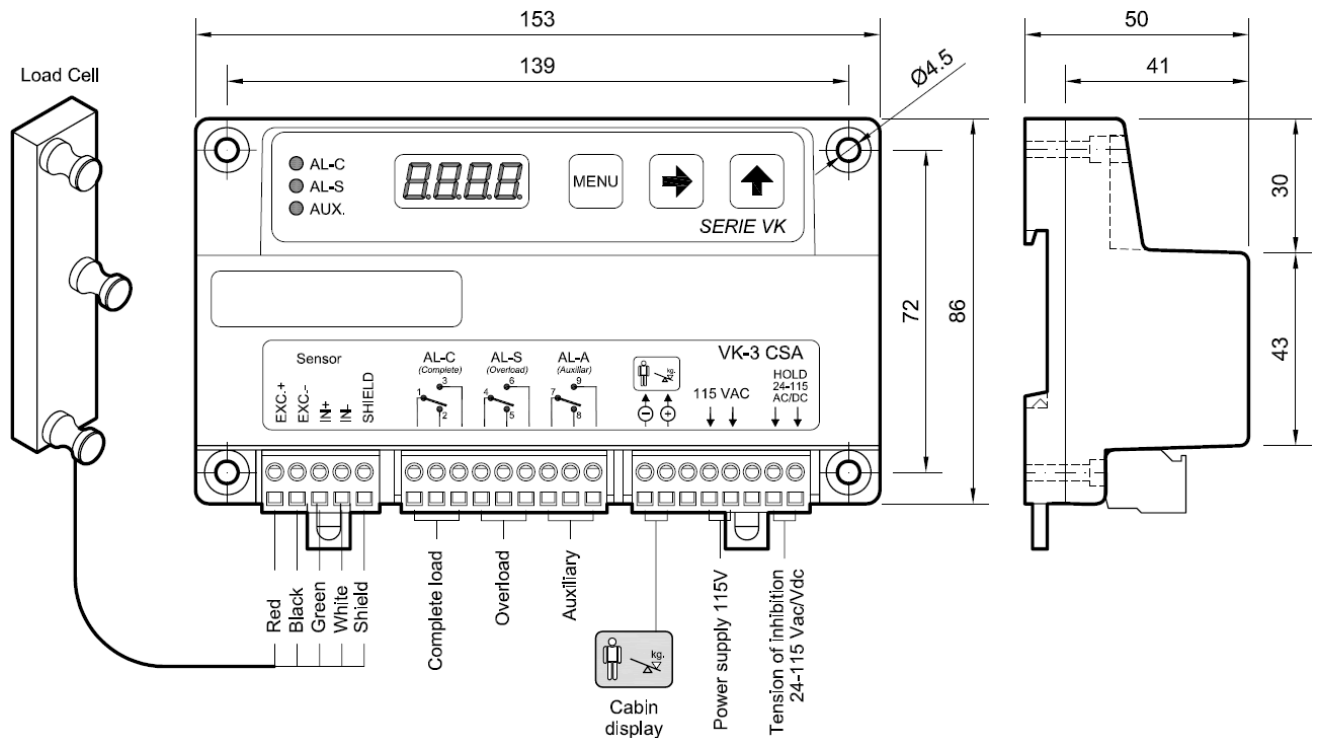

## 4. Contents

1 pc- VK-3 Controller, 1 pc- DIN Rail Mount, 2 pc- Rail Mounting Screws  
1 pc- Terminal Tool/Key

## 5. Description of Connections

**AL-C**, **AL-S** and **AL-A** (if provided) are the relays that change state when the programmed weight values are exceeded.

- **AL C** is usually programmed for the capacity of the cab. When the load in the cab exceeds this value the relay changes state and if using our MB-D display the figure will illuminate as the load increases.
- **AL S** is usually programmed for overload. When the load in the cab exceeds this value the relay changes state and if using our MB-D display it will activate a buzzer and the KG marking of the display will illuminate.
- **AL A** is an extra relay to be programmed as needed. When the load in the cab exceeds this value the relay changes state.

**Hold** is a circuit that requires 24-110VAC or VDC power. The power is to be applied when the doors close and the power is to be removed when the doors open. When power is applied the control stops weighing and the weight value will blink on the display. This insures that movement of the cab will not affect the weighing process. Also, when the doors are closed since no more people will be entering the cab there is no reason to continue the weighing process. When the doors open, power is to be removed from the hold circuit so that the control can begin measuring the load in the cab.

**Power Supply** required to operate the controller is shown above the terminals. Standard voltages are 24VDC, 110VAC and 220VAC depending on the control ordered.

**Sensor** connections are shown above the terminals on the controller corresponding to the load sensor/cell used.

**Cabin Display-** Our MB-D Display is the factory supplied display that can be used with the VK Series of controllers. Based upon the setting of AL-C relay the figure will progressively illuminate starting at the feet and travel up the body of the figure. Upon reaching the setting of AL-C the complete figure will be illuminated. The KG marking will illuminate and a buzzer will sound upon reaching the AL-S relay setting of the control. If you want to use your own buzzer or LED display connect to these terminals. These terminals provide 0-7.5 VDC at 75mA maximum based upon the settings of the AL-C and AL-S settings. When connecting your own buzzer or LED display follow polarity as shown on terminals.

## 6. Programming Keys

 - Pressing the menu key scrolls through the various programmable parameters of the control.

 - Pressing this key enters the specific parameter you are going to program. Once the specific parameter is displayed, pressing this key highlights the digit to be modified.

 - Pressing this key will modify the specific digit.

## 7. Menu/Programming Order



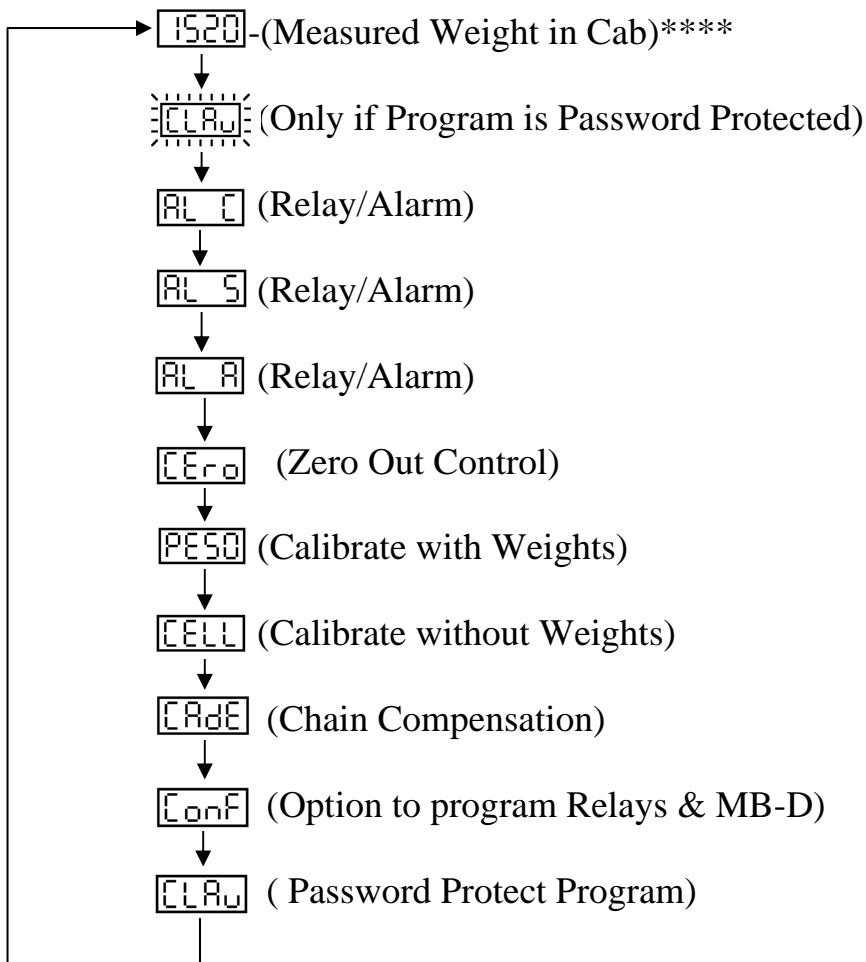

Pressing the  Key will scroll through the program in the following order:



\*\*\*\*\*Note: Actual value displayed varies with load in cab













## 8. How to Program

### Button/Key Operation

- Press the  key until the display shows the desired parameter to be changed.
- Press the  key to highlight the specific digit to be modified. The digit to be modified will blink.
- Press the  key to change the specific digit.
- Press the  key twice to save the new value. Once a value is saved the control will display the next parameter.
- If you do not press the  key twice the changes will not be stored and the controller display will remain at the parameter you were modifying.

## 9. Calibration

### Manual Calibration with Weights

1. Before programming or calibrating sensors and control:
  - Bring cab to middle floor of its total travel. For instance, if travel is 6 stops or floors place cab on the 3<sup>rd</sup> or 4<sup>th</sup> floors.
  - Bounce in cab to insure cab is free on guide rails.
2. Properly connect the sensors to control.
3. Power up control and check power supply to control and insure within voltage range of the control supplied.
4. Install sensors to cable per instructions supplied with sensors.
5. Zero out the controller:
  - Press  key till  is displayed.
  - Press  key once.
  - Press  key once.
  - Controller display will begin to count down. Exit top of cab till unit finishes counting down.
  -  should be shown on the display. If  is not shown the value has not been saved in the controller and this step must be done again.
6. Adjust for weights:
  - Press  key till  is displayed if it is not shown.
  - Add a known weight to the car. Preferably a minimum of 50% of the car capacity.
  - Press:  and  keys to manually enter the value in kilograms of the weight in the cab.
  - Press  key twice.
  - As controller display begins to count down, exit top of cab till unit finishes counting down.
  - Press the  key until the weight is shown on control display. It should be the value of the weights in the cab in kilograms.

7. Set **AL C** Contact trip level:
  - Press **MENU** key till **AL C** is displayed.
  - Press **→** and **↑** keys to set contact trip point values. Put the value in kilograms of the weight that will activate the relay. Usually for the AL-C contact the capacity of the cab is used.
  - Press **MENU** key twice to save these settings.
  - Connect to **AL-C** terminals for normally open and/or normally closed relay per diagram on controller.
8. Repeat **Step 7** for the other contacts to be used **AL S** is normally the overload setting and **AL A** is an auxiliary contact to be set as needed by customer.
9. Complete any other wiring including hold circuit and any other auxiliary programming.

### **Auto Calibration without Weights (CH or CHD Hydraulic Sensors Must Use Manual Calibration)**









1. Before programming or calibrating sensors and control:
  - Bring cab to middle floor of its total travel. For instance, if travel is 6 stops or floors place cab on the 3<sup>rd</sup> or 4<sup>th</sup> floors.
  - Bounce in cab to insure cab is free on guide rails.
2. Properly connect the sensors to control
3. Power up control and check power supply to control and insure within voltage range of the control supplied.
4. Install sensors to cable per instructions supplied with sensors.
5. Zero out the controller:
  - Press **MENU** key till **CEr0** is displayed.
  - Press **→** key once.
  - Press **MENU** key once.
  - Controller display will begin to count down. Exit top of cab till unit finishes counting down.
  - **PES0** should be shown on the display. If **PES0** is not shown the value has not been saved in the controller and this step must be done again.
6. Enter **CELL** Value by:
  - Press **MENU** key till **CELL** is displayed.
  - Locate the CELL value shown on the connection box of the sensors.
  - Press the **→** key once.
  - Press the **→** key and **↑** key to enter the **CELL** value shown on the connection box of the sensors into the controller. If 2:1 roped application double the value of the cell shown on the connection box of the sensors.
  - Press the **MENU** twice to save the CELL value in the controller.
  - **CRdE** should be shown on the display. If **CRdE** is not displayed the value of the CELL has not been saved and this step must be done again.

7. Set **AL C** Contact trip level:
  - Press **MENU** key till **AL C** is displayed.
  - Press **→** and **↑** keys to set contact trip point values. Put the value in kilograms of the weight that will activate the relay. Usually for the AL-C contact the capacity of the cab is used.
  - Press **MENU** twice to save these settings.
  - Connect to **AL C** terminals for normally open and/or normally closed relay per diagram on controller.
8. Repeat **Step 7** for the other contacts to be used. **AL S** is normally the overload setting and **AL A** is an auxiliary contact to be set as needed by customer.
9. Complete any other wiring including hold circuit and any other auxiliary programming.

## 10. Auxiliary Options:

- **CRdE** is allows you to enter a value if there is compensation chain on the elevator. The maximum value that can be entered for compensation chain is 50kg. To enter a value for compensation chain into the control:
  - Press the **MENU** key till **CRdE** is displayed.
  - Press the **→** and **↑** keys to enter the compensation chain value you desire.
  - Press the **MENU** key twice to save the value in the controller.
  - **CONF** should be shown on the display. If **CONF** is not displayed the value for the compensation chain is not saved and this step must be done again.
- **CONF** This option allows you to program the relays and MB-D Display different than supplied by the factory. See factory for details.
- **CLRW** This option allows you to enter a code to prevent unwarranted programming of the controller. Before changing the access code number it is important that the number is saved and remembered. If the new code is lost you will not be able to program the controller. The factory value for this setting is 0000. To prevent access to the programming of the controller:
  - Press the **MENU** key until **CLRW** is displayed.
  - Press the **→** key and **↑** key to enter the new code number limit access to the controller program.
  - Press the **MENU** key twice to save the value in the controller.
  - The amount of weight in the cab should be shown on the display. If not, the new access code number has not been saved and this step must be done again.
  - **CLRW** is activated by pressing and holding the **MENU** key for three (3) seconds until the display only shows a moving segment or when controller enters energy saving mode on its own.

## 11. Troubleshooting and Errors

- **The display shows moving segments only-** The controller has a energy saving circuit. This occurs when power is supplied and no programming occurs within three (3) minutes or when programming is completed and controller is operating untouched for one (1) hour. To return to the normal display mode, press  key once.
- **Elevator will not run-** Check for any **Err codes** on the display. If there are any Err codes read this section further. If no Err codes, check all controller connections. Insure the proper voltage is provided to power connections of VK controller. Inspect all relay connections and insure they are secure at the VK controller and other corresponding external connection points. Insure all relay connections are correct to allow operation of elevator by reviewing wiring diagrams and confirm whether a normally open or normally closed relay is required. Then check the proper voltage is supplied to the hold circuit and insure the proper sequence of power **is** applied to the hold circuit. Then check fuse. To check fuse, disconnect power to the controller, open the controller by removing the five (5) screws that hold the cover, remove fuse from vertical free mounting (black) fuse holder next to controller transformer and replace with new fuse.
- When I try to program unit  is shown on the display- Controller has been previously programmed with password protection to prevent unauthorized changes to the program. Locate four (4) digit password and enter into controller when  is blinking on the display. To enter the password, press the  key to highlight the digit to be changed and press the  key to change the specific digit highlighted. Press key once to continue programming controller. If you cannot locate your password contact the factory.
-  = Bad load cell connection or damaged load cell- Correct error condition by checking all load cell connections to the controller are per wiring diagram along with inspecting cables for any cuts or broken wires.
-  =Negative load cell flow- Correct error condition by checking load cell connections to the controller and insure they are per wiring diagram.
-  =Positive load cell flow- Load cells are to small for application and must be replaced with proper units.
-  = Polarity error- Correct error condition by checking all load cell connections to the controller are per wiring diagram and reprogram control and recalibrate per Paragraph 9.

**Err5** = MB-D display short- Correct condition by locating short. Disconnect MB-D display, turn off the controller and reconnect the MB-D display.

**Err6** = Parameter values have been lost ( AL-C, AL-S, AL-A, CERO, PESO...)  
Scroll through menu and check parameter values. If necessary reprogram and calibrate per Paragraph 9.

**Err7** = Sensitivity of load cell is small. Recalibrate and reprogram **Err0** operation, add known weight into car and reprogram **PESO** operation per Paragraph 9.

**FOR ANY FURTHER ASSISTANCE OR IF ANY QUESTIONS CONTACT:**

**ELEVATOR SYSTEMS  
465 ENDO BLVD. GARDEN CITY, NY 11530  
E-MAIL: [ORDERS@ELEVATORSYSTEMS.COM](mailto:ORDERS@ELEVATORSYSTEMS.COM)**

**ESI ELEVATOR  
SYSTEMS**